



**AMENITY PUBLIC SCHOOL  
HOLIDAY HOMEWORK (2026-27)  
CLASS XI SCIENCE**



*Summer vacation is not only a time to relax, but also an opportunity to refresh your mind, discover new interests, and prepare yourself for the journey ahead. Use this break wisely to grow, recharge, and return stronger than before.*

*“The quiet moments of rest today often become the foundation of tomorrow’s success.”*

Dear Students,

The long-awaited summer holidays are finally here! While it is important to enjoy and unwind, it is equally essential to remain productive and make meaningful use of your time. A healthy balance between enjoyment and learning will help you come back motivated, energetic, and ready for new challenges.

Here are a few suggestions to make your vacation enjoyable as well as valuable:

- 1. Strengthen Your Studies:** Revise important concepts and complete all pending assignments or projects on time.
- 2. Explore Your Interests:** Spend time developing hobbies such as sketching, dancing, reading, singing, photography, or creative writing.
- 3. Stay Active and Healthy:** Reduce unnecessary screen time and include physical activities like sports, exercise, yoga, or outdoor games in your routine.
- 4. Develop Reading Habits:** Read books, newspapers, journals, or magazines regularly to improve your knowledge and vocabulary.
- 5. Take Care of Your Well-being:** Practice meditation, mindfulness, or other calming activities. Spend meaningful time with family and friends and create beautiful memories together.

*Let your imagination shine bright,  
Keep learning with curiosity and delight.  
Stay healthy, active, and full of cheer,  
And make this summer your best one this year.*

**Wishing You a Joyful and Refreshing  
Summer Vacation!**

***“Reading is a conversation with minds across time.”***

**GENERAL INSTRUCTIONS:**

- *Attempt all the tasks creatively and neatly in your CREATIVE WRITING NOTEBOOK.*
- *Maintain originality in presentation and content.*
- *Support your answers with illustrations, pictures, newspaper cuttings, quotations or creative borders wherever suitable.*
- *Handwriting, presentation and language accuracy will be assessed.*

❖ **ENGLISH CORE (301)**

**1. SPEECH WRITING**

**Topic:** ‘Energy Lockdown Today for a Secure Tomorrow’

Prepare a 150-200 word speech on "Energy Lockdown Today for a Secure Tomorrow" addressing global energy concerns, citizen roles, and practical solutions. Also, include a small, creative slogan/poster, as a prop to support your speech.

**2. BOOK REVIEW**

Write a comprehensive Book Review of any book you have recently read (Word limit: 150-200 words). Your review must follow the standard format, including the Book Title & Author, a brief Plot Summary/Theme, an analysis of the Core Message/Life Lessons learned, and your Personal Recommendation.

(You may choose to review insightful non-fiction like Atomic Habits, deep classics like To Kill a Mockingbird, or impactful stories like The Alchemist).

**3. POSTER DRAFTING**

**Topic:** ‘Digital Detox - Reconnect with Real Life’

Design a poster on "Digital Detox Reconnect with Real Life" highlighting the harmful effects of excessive screen time and the importance of balance. Your poster must include a creative title, catchy slogan, relevant illustrations, and a short list of Dos & Don'ts for healthy gadget alternatives.

**4. CLASSIFIED ADVERTISEMENT PROJECT**

Collect and paste one real example from the newspaper or create your own for the seven core classified categories (including Situation Vacant, To Let, and Matrimonial). Neatly organize them in your creative writing notebook with clear category labels, highlight their structural features, and design one original classified advertisement of your own.

## 5. DEBATE WRITING

The Delimitation Bill, aimed at redrawing legislative boundaries based on demographic changes, has sparked an intense national discourse regarding fair political representation versus potential regional imbalances. Write a debate in 150-200 words either FOR or AGAINST the motion: 'The Delimitation Bill is a necessary step for democratic equity rather than a threat to regional federalism.'

### ❖ MATHEMATICS (041)

- Do Question Bank given in your class group.
- Do three activities in Maths Lab Manual
  1. To find the number of subsets of a given set and verify that if a set has 'n' number of elements, then the total number of subsets will be  $2^n$ .
  2. To verify that for two non-empty finite sets A and B: If  $n(A) = p$  and  $n(B) = q$ , then the total number of relations from A to B is equal to  $2^{pq}$ , that is,  $n(A \times B) = pq$  and  $2^{n(A \times B)} = 2^{pq}$ .
  3. To represent set theoretic operations using Venn diagrams.

### ❖ BIOLOGY (044)

Prepare a detailed research paper, PPT and Spiral bound file from the topic of your choice.

#### List of Investigatory projects

- Effect of light intensity on seed germination.
- Study of phototropism in plants.
- Effect of different fertilizers on plant growth.
- Comparative study of growth in monocot and dicot seedlings.
- Role of earthworms in improving soil fertility.
- Effect of salinity on seed germination.
- Study of transpiration rate under different environmental conditions.
- Hydroponics versus soil cultivation: A comparative study.
- Effect of pH on plant growth.
- Analysis of food habits and nutritional status of teenagers.
- Any case study of disease of your choice.

**Complete the Investigatory project and compile it according to the prescribed format.**

- Cover page
- Certificate

- Acknowledgment
- Index
- Introduction
- Content (including pictures/graphs/tables/survey report etc.)
- Case Study
- Bibliography
- **Assessment Criterion-** Content, Presentation, Research Work, Case study, Viva-voce and Confidence.
- It is an individual activity and marks will be awarded in the **Internal Examination**.

## ❖ **CHEMISTRY (043)**

### **INVESTIGATORY PROJECT:**

Make an investigatory project file which is required for final examination for Chemistry practical. Students should prepare investigatory project according to roll no as given below.

✓ **Roll no:- 1, 7, 13, 19, 25, 31, 37, 43, 49, 55**

Waste to chemicals: Transforming wastes and residues to energy, fuels and other useful chemicals.

✓ **Roll no:- 2, 8, 14, 20, 26, 32, 38, 44, 50**

International standard of drinking water

✓ **Roll no:- 3, 9, 15, 21, 27, 33, 39, 45, 51**

Nobel laureates in Chemistry (any 5): Their Life and works

✓ **Roll no:- 4, 10, 16, 22, 28, 34, 40, 46, 52**

Green House Effect

✓ **Roll no:- 5, 11, 17, 23, 29, 35, 41, 47, 53**

Waste water recycling

✓ **Roll no:- 6, 12, 18, 24, 30, 36, 42, 48, 54**

Acid Rain

### ***General Instructions:***

- The report can be typed/ handwritten, with pictures
- Write only on one side of the sheet.
- Use A-4 colored or white sheets, whichever easily available.

### **To Write The Practicals of:**

- Titration of M/20 HCl Vs sodium hydroxide
- Titration of M/20 Oxalic Acid Vs sodium carbonate.

## ❖ PHYSICS (042)

### E- POTENTIAL & CAPACITANCE

#### ✚ Assignment based on Vectors

Solve the given subjective and objective questions (Q.no. 1 to 31)

- Two vectors are  $\vec{A} = 2\hat{i} + \hat{j} + 3\hat{k}$  and  $\vec{B} = -\hat{i} + 2\hat{j} - 2\hat{k}$  find the magnitude and unit vector in the following cases-
  - $\vec{A}$
  - $\vec{B}$
  - if both vectors are parallel
  - if both vectors are opposite.
- Let  $\vec{A} = 4\hat{i} + 3\hat{j}$  and  $\vec{B} = 3\hat{i} + 4\hat{j}$ . Find the magnitudes of:
  - $\vec{A}$
  - $\vec{B}$ ,
  - $\vec{A} + \vec{B}$
  - $\vec{A} - \vec{B}$
- Two vectors are given by  $\vec{a} = (4.0\text{m})\hat{i} - (3.0\text{m})\hat{j} + (1.0\text{m})\hat{k}$  and  $\vec{b} = (-1.0\text{m})\hat{i} + (1.0\text{m})\hat{j} + (4.0\text{m})\hat{k}$  In unit-vector notation, find (a)  $\vec{a} + \vec{b}$  (b)  $\vec{a} - \vec{b}$ , and (c) a third vector such that  $\vec{a} - \vec{b} + \vec{c} = 0$ .
- A person walks in the following pattern; 3.1 km north, then 2.4 km west, and finally 5.2 km south.
  - Sketch the vector diagram that represents this motion.
  - How far?
  - In what direction would a bird fly in a straight line from the same starting point to the same final point?
- (a) In unit-vector notation, what is the sum  $\vec{a}$  and  $\vec{b}$  if  $\vec{a} = (4.0\text{m})\hat{i} + (3.0\text{m})\hat{j}$  and  $\vec{b} = (-13.0\text{m})\hat{i} + (7.0\text{m})\hat{j}$ ? What is the (b) magnitude and (c) direction of  $a + b$ ?
- The three vectors in (Fig.) have magnitudes  $a = 3.0\text{ m}$ ,  $b = 4.0\text{ m}$ ,  $c = 10.0\text{ m}$  and angle  $\theta = 30.0^\circ$ . What are?
  - The  $x$ - component and  $y$ - component of  $\vec{a}$
  - $x$ - component and  $y$ - component of  $\vec{b}$
  - The  $x$ -component and  $y$ -component of  $C$ ? If  $C = p\vec{a} + q\vec{b}$ , what are the values of  $p$  and  $q$ ?

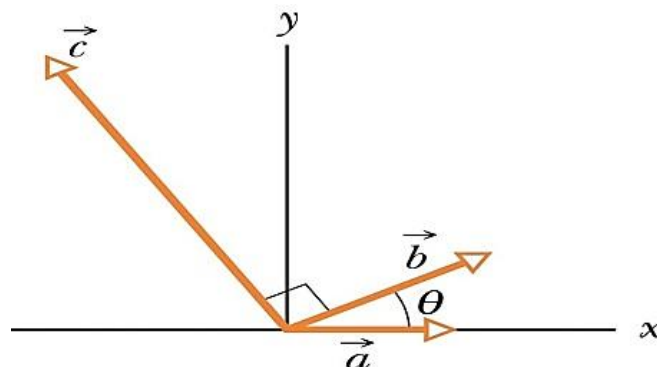

7. Find the resultant of the three vectors shown in the figure.

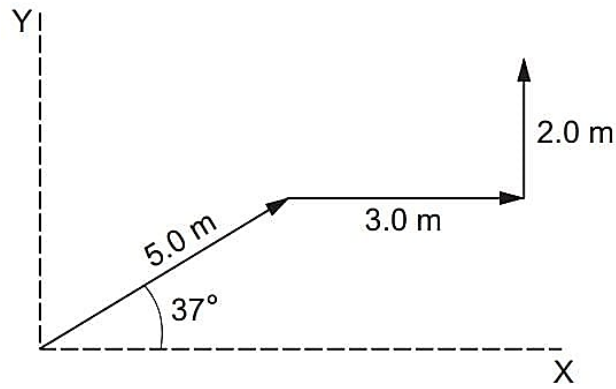

8. Refer to figure. Find:

(a) the magnitude,

(b) x and y components and

(c) the angle with the X-axis of the resultant of  $\vec{OA}$ ,  $\vec{BC}$  and  $\vec{DE}$ .

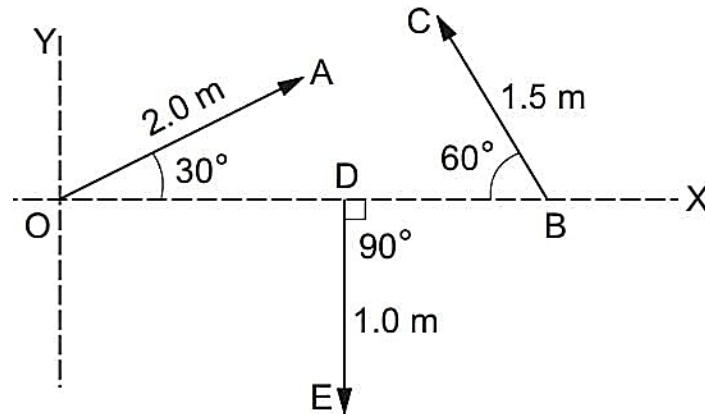

9. The sum of the three vectors shown in the figure is zero. Find the magnitudes of the vectors OB and OC.

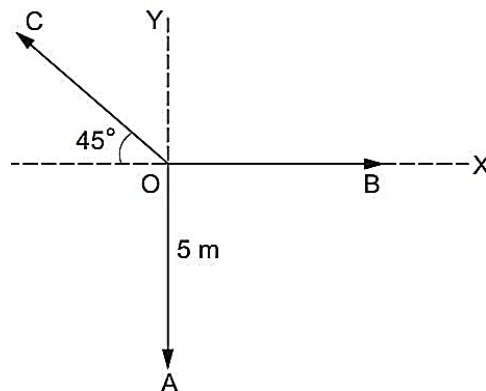

10. The magnitudes of  $\vec{OA}$ ,  $\vec{OB}$  and  $\vec{OC}$  in the figure are equal. Find the direction of  $\vec{OA} + \vec{OB} - \vec{OC}$ .

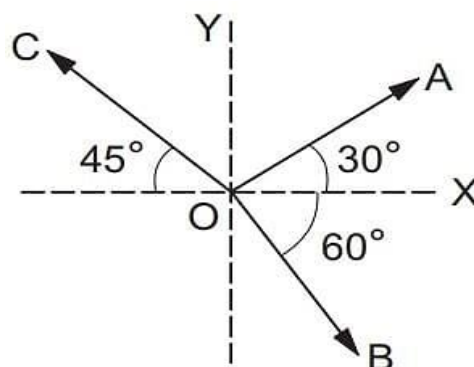

11. Find the resultant of system of forces acting at in Figure?

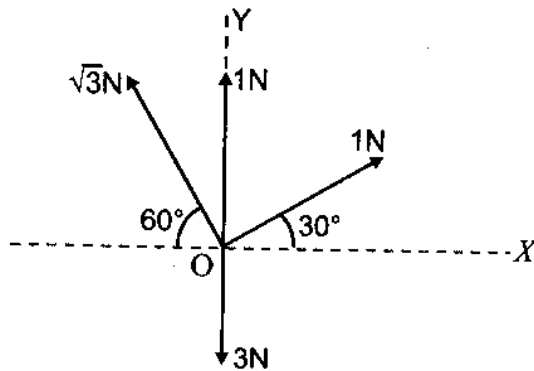

12. Two forces each equal to  $F$ , act on a particle as shown in Figure. Find the resultant force?

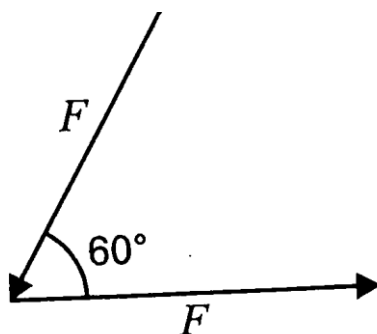

13. Find the resultant of the three vectors  $OA$ ,  $OB$  and  $OC$  shown in figure. The radius of the circle is  $R$ .

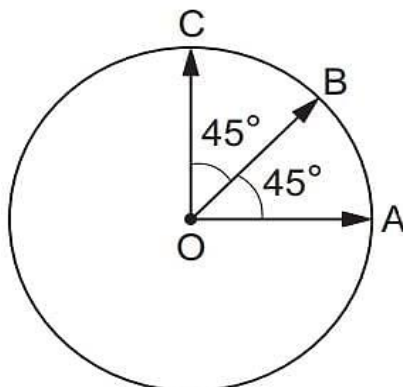

14. The resultant of vectors  $\overrightarrow{OA}$  and  $\overrightarrow{OB}$  is perpendicular to  $\overrightarrow{OA}$  (in the given figure). Find the angle  $AOB$

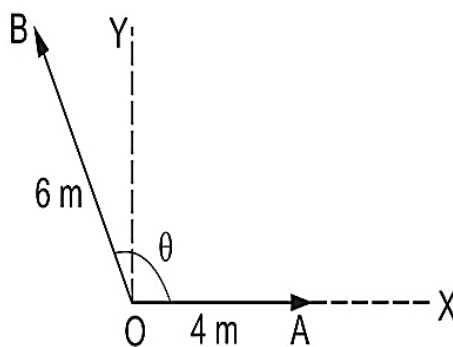

15. Two vectors have magnitudes 3 unit and 4 units respectively. What should be the angle between them if the magnitude of the resultant is:

(a) 1 unit

(b) 5 unit

(c) 7 unit

16. For the displacement vectors  $\vec{a} = (3.0\text{m})\hat{i} + (4.0\text{m})\hat{j}$  and  $\vec{b} = (5.0\text{m})\hat{i} + (-2.0\text{m})\hat{j}$ , give  $\vec{a} + \vec{b}$  in: (a) unit-vector notation, and as (b) a magnitude and (c) an angle (relative to  $\hat{i}$ ). Now give  $\vec{a} - \vec{b}$  (d) unit-vector notation, and as (e) a magnitude and (f) an angle.

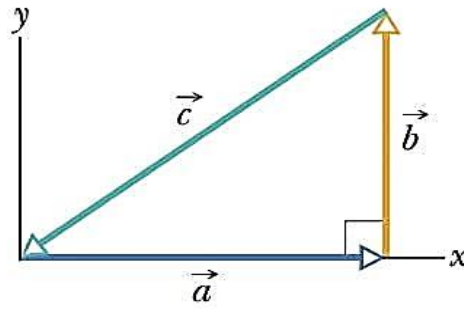

17. For the vectors in Fig. with  $a = 4$ ,  $b = 3$ , and  $c = 5$ , what are  
 (a) The magnitude and the direction of  $\vec{a} \times \vec{b}$   
 (b) The magnitude and the direction of  $\vec{a} \times \vec{c}$   
 (c) The magnitude and the direction  $\vec{b} \times \vec{c}$ ? (The  $z$  axis is not shown.)
18. Two vectors are presented as  $\vec{a} = (3.0\text{m})\hat{i} + (5.0\text{m})\hat{j}$  and  $\vec{b} = (2.0\text{m})\hat{i} + (4.0\text{m})\hat{j}$ . Find (a)  $\vec{a} \times \vec{b}$ , (b)  $\vec{a} \cdot \vec{b}$ , (c)  $(\vec{a} + \vec{b}) \cdot \vec{b}$  and (d) the component of  $\vec{a}$  along the direction of  $\vec{b}$ .
19. Three vectors are given by  $\vec{a} = 3.0\hat{i} + 3.0\hat{j} - 2.0\hat{k}$ ,  $\vec{b} = -1.0\hat{i} - 4.0\hat{j} + 2.0\hat{k}$ , and  $\vec{c} = 2.0\hat{i} + 2.0\hat{j} + 1.0\hat{k}$ . Find:  
 (a)  $\vec{a} \cdot (\vec{b} \times \vec{c})$ , (b)  $\vec{a} \cdot (\vec{b} + \vec{c})$ , and (c)  $\vec{a} \times (\vec{b} + \vec{c})$ .
20. For the following three vectors, what is  $3\vec{c} \cdot (2\vec{a} \times \vec{b})$ ?  
 $\vec{a} = 2.0\hat{i} + 3.0\hat{j} - 4.0\hat{k}$ ,  $\vec{b} = -3.0\hat{i} + 4.0\hat{j} + 2.0\hat{k}$ ,  $\vec{c} = 7.0\hat{i} - 8.0\hat{j}$ .
21. Use the definition of scalar product,  $\vec{a} \cdot \vec{b} = ab \cos\theta$ , and the fact that  $\vec{a} \cdot \vec{b} = a_x b_x + a_y b_y + a_z b_z$  to calculate the angle between the two vectors given by  $\vec{A} = 3.0\hat{i} + 3.0\hat{j} + 3.0\hat{k}$  and  $\vec{B} = 2.0\hat{i} + 1.0\hat{j} + 3.0\hat{k}$ .
22. If  $|\vec{A} \times \vec{B}| = |\vec{A} \cdot \vec{B}|$ , find the angle between  $\vec{A}$  and  $\vec{B}$ ?
23. If  $\vec{A} = 3.0\hat{i} + 4.0\hat{j}$  and  $\vec{B} = 7.0\hat{i} + 24.0\hat{j}$ , find a vector is having same magnitude as  $\vec{B}$  and parallel to  $\vec{A}$ ? Also find the projection of  $\vec{B}$  on  $\vec{A}$ .
24. Find a value of  $p$  in the unit vector  $0.4\hat{i} + 0.8\hat{j} + p\hat{k}$ ?
25. If vectors P, Q and R have magnitude 5, 12 and 13 units and  $\vec{P} + \vec{Q} = \vec{R}$ , find the angle between Q and R?
26. For any two vectors  $\vec{A}$  and  $\vec{B}$ , if  $|\vec{A} \times \vec{B}| = \vec{A} \cdot \vec{B}$ , find the magnitude of  $\vec{C} = \vec{A} + \vec{B}$ ?
27. What is the angle between  $(\vec{P} + \vec{Q})$  and  $(\vec{P} \times \vec{Q})$ ?  
 (a) 0 (b)  $\pi/2$  (c)  $\pi/4$  (d)  $\pi$



12. Write a program to calculate electricity bill according to the following rules:
- First 100 units: ₹ 5 per unit
  - Next 100 units: ₹ 7 per unit
  - Remaining units: ₹ 10 per unit
13. Write a program to input marks in five subjects, calculate percentage, and display division:
- 75% and above: Distinction
  - 60%–74%: First Division
  - 45%–59%: Second Division
  - 33%–44%: Third Division
  - Below 33%: Fail
14. Write a program to check whether three sides can form a valid triangle.
15. Write a program to classify a triangle as Equilateral, Isosceles, or Scalene.

### **For Loop-Number-Based Programs**

16. Write a program to display numbers from 1 to 100 along with their squares.
17. Write a program to find the sum of the first n natural numbers.
18. Write a program to display the multiplication table of a given number.
19. Write a program to calculate the factorial of a number.
20. Write a program to count the number of factors of a given number.
21. Write a program to check whether a number is prime.
22. Write a program to display all prime numbers between 1 and n.
23. Write a program to generate the Fibonacci series up to n terms.
24. Write a program to find the sum of all even numbers between 1 and n.
25. Write a program to reverse a number using a loop.

### **Pattern Programming Using for Loop**

26. Write a program to display the following pattern:

```
*
**
***
****
*****
```

27. Write a program to display the following pattern:

```
1
12
123
1234
12345
```

28. Write a program to display the following pattern:

```
*****
****
***
**
*
```

29. Write a program to display the following pattern:

```
A
AB
ABC
ABCD
ABCDE
```

30. Write a program to display all Armstrong numbers between 100 and 999.

## ❖ **PSYCHOLOGY (037)**

### **1. Book/Movie Review on a Psychological Theme**

Students are required to either read a book or watch a movie/web series episode based on a psychological theme and prepare a 150-200 word report.

#### **Instructions:**

Your report should include:

- Name of the book/movie
- Main psychological theme/topic covered
- Explanation of the psychological concept
- Important behaviour or incidents noticed
- Your personal opinion/views about the story and characters
- What you learned from it psychologically

**Word Limit:** 150–200 words

#### **Presentation:**

- Handwritten or typed
- Proper heading and neat format
- Add pictures/poster (optional)

## **Suggested Books**

- The Diary of a Young Girl – emotions, stress, resilience
- Wings of Fire – motivation and determination
- The Alchemist – dreams, self-belief, personality
- Ikigai – happiness and mental well-being
- Tuesdays with Morrie – emotions and human relationships

## **Suggested Movies**

- Taare Zameen Par – learning disability, intelligence
- Inside Out – emotions and emotional balance
- Dear Zindagi – mental health and counselling
- The Pursuit of Happyness – motivation and resilience
- 3 Idiots – stress, education pressure, creativity
- Chhichhore – peer pressure and emotional strength

## **2. Creative Psychology Activity**

- Prepare any ONE creative work related to the topics studied in Chapters 1 and 2 (or a topic of your choice).

Students may choose ANY ONE of the following:

(Chart, Poster, Model, Slogan Writing, Comic Strip, Collage)

### **Submission Format:**

- A3/A4 sheet or model form.
- Name, class, and topic should be clearly written (Optional)  
Additional Question: Conduct a Psychological Survey
- Students are required to conduct a small survey on any ONE psychological or social topic related to everyday life.

### **Instructions:**

- Choose any one topic of your interest.
- Prepare 5–8 survey questions (objective or short answer type).
- Conduct the survey with at least 10–15 people (friends, classmates, family members, neighbours, etc.).
- Record the responses neatly in tabular form.
- Analyse the responses and write your conclusion.

### **Your survey report should include:**

- Title of the Survey
- Objective/Purpose
- Survey Questions
- Number of Participants
- Response Table/Graph
- Analysis of Responses
- Conclusion (What did you learn from the survey?)

## ❖ PAINTING (049)

1. Make four drawings out of the given pictures.



2. Make a poster on any of the given topics.

- Mandala Art
- Aipan Art

## ❖ MUSIC (034)

Write these topics on your project file-

1. Single, double and fourer of the talas given below:

Ektaal, Teental

2. Raga compositions:

**Raga Bhairav—Fast Khyal (Drut)-Teen Tala**

1	2	3	4	5	6	7	8	9	10	11	12	13	14	15	16
x				2				0				3			
				<b>Sthai :</b>											
P - G M				R - S -				G M D -				P D M M			
ba h ni t				ja - go -				Ja - go -				su ba h su			
Ṡ N D P				MP DP M G				N S G M				P D N Ṡ			
me - chi t				la - go -				Pra bh u ke -				cha r na n			
				<b>Antra :</b>											
Ṡ - Ṡ Ṡ				Ṙ Ṙ Ṡ -				M - P P				D - N N			
Pa r ma -				ta m ka -				Dh ya n dha				ro - U s			
G - G M				R - S -				Ṡ N D P				P - P -			
ka ro - bai				ra - go -				Ma nn me -				Pai - da -			

Composed by : Subhash Duggal

**Composition**

**Sthai :** Jago Subah Subah Nit Jago,  
Prabhu ke Charnan Me Chit Lago.

**Antra :** Dhyan Dharo Us Parmatam ka,  
Mann me Paida Karo Bairago.

**Raga Bhairav—Slow Khyal (Vilambit)-Ek Tala**

1	2	3	4	5	6	7	8	9	10	11	12		
x			0			2		0		3		4	
										<b>Sthai :</b>			
R- -R			S- --			GM P-GM		D- PP		G-MM R-S-		SR -S	
ro -pra			bhu --			mujh aajiz		pa r poo		ri,kro aas-		Kripa -k	
										<b>Antra :</b>			
Ṡ- Ṡ-ṠṠ			Ṙ- Ṡ-ṄṠ			D- --		P- G-GM		R- S-		MMPP D-NN	
ha rikroon			pra bhu,sun			lee --		jo - -ar		daa S-		Nituth aas,ti	

Composed by : Prof. Shamshad Ali

**Composition**

**Sthai :** Kripa Karo Prabhu,  
Mujh Aajiz Par, Poori Karo Aas.

**Antra :** Nit Uth Aas Tihari karoon,  
Prabhu Sun Leejo Ardaas.